

# VOSS.mini.PET „GARFIELD“ 26505

1

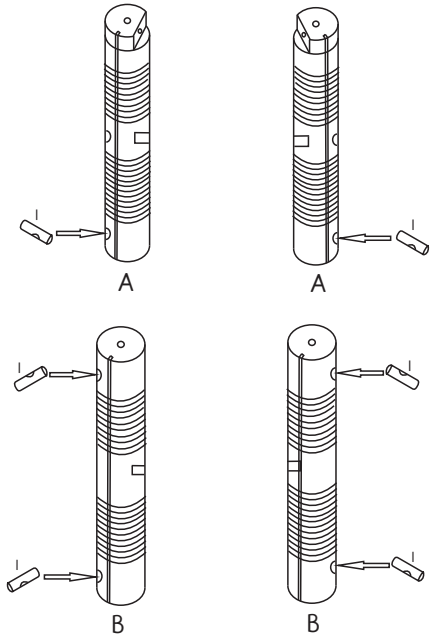

Insert Part I inside the 6 holes of Posts A and B, ensure the hole in Part I is aligned with the internal thread in the Posts A and B.

Stecken Sie bitte jeweils die Teile I in die 6 Löcher der Stämme A und B. Stellen Sie sicher, dass die Löcher von Teil I so ausgerichtet sind, dass diese mit dem Innengewinde der Stämme A und B übereinstimmen.

2

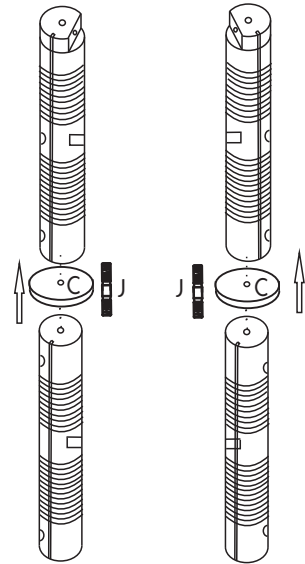

3

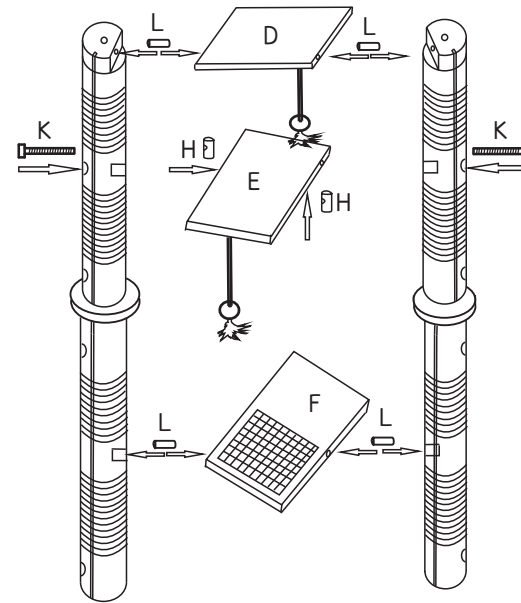

Insert Part H into the 2 holes on the back of the Part E, ensure the hole in the Part H is aligned with the Bolt K.

Stecken Sie bitte die Teile H in die beiden Löcher, die sich auf der Rückseite von Platte E befinden. Stellen Sie sicher, dass die Löcher der Teile H in Richtung Schraube K zeigen.

4

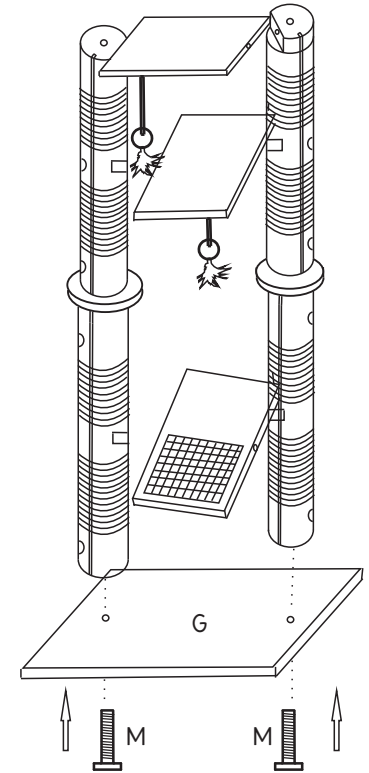

2x A  8x59 cm

2x B  8x59 cm

2x C 

1x D  30x25 cm

1x E  30x25 cm

1x F  60x25 cm

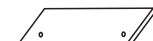
1x G  40x40 cm

2x H  metal

6x I  metal

2x J  Ø 8x90 cm

2x K  Ø 6x65 cm

4x L  woodnog/Holzdübel

2x M  Ø 8x60 cm

2x N 